

Manual for RC4



Contents

Product Information	6
<i>Facts</i>	6
<i>PC program</i>	6
<i>Serial number</i>	6
<i>Initial operation</i>	6
<i>Power on crank or flywheel</i>	6
<i>Adjustments of the recumbent</i>	7
<i>Recumbent settings</i>	7
Cycle adjustments	7
<i>Power on crank or flywheel</i>	8
<i>Calories</i>	8
<i>Validation</i>	8
Pulse function	9
<i>Pulse standard (chest belts)</i>	9
<i>Pairing display and chest belt</i>	9
Display Description	10
<i>Sleep mode</i>	10
<i>Personal settings</i>	11
<i>Alternative power / force display</i>	11
User settings	12
<i>Units</i>	12
<i>Cycle constant</i>	12
<i>Metronome cadence</i>	12
<i>BikeID</i>	13
<i>Base Power</i>	13
<i>Steady State HR</i>	13
Calibration	14
<i>Manual motor control</i>	14
<i>Current potentiometer value</i>	14
<i>Zero adjustment of scale</i>	15
<i>Calibration pendulum</i>	16
<i>Calibration electronics</i>	16
Training	18
METS	19
Astrand	20
YMCA	22
Increment	24
PWC	26
Testing using RC4	28
<i>Test person enforcement</i>	28
<i>Reviewing results</i>	29
Troubleshooting guide	30
Service	32
<i>Service check and Maintenance</i>	32
<i>Batteries</i>	33
<i>Flywheel bearing</i>	33
<i>Crank bearing</i>	33
<i>Transportation</i>	33
<i>Replacement of brake belt</i>	33
<i>Brake belt contact surface</i>	33
<i>Chain 1/2" x 1/8"</i>	34
<i>Freewheel sprocket</i>	35
Spare parts list	36

Important

Read the manual carefully before using the cycle and save it for future use.

Monark Exercise AB

Monark has 100 years' experience of bicycle production. The Monark tradition has yielded know-how, experience, and a real feel for the product and quality. Since the early 1900s, Monark bikes have been living proof of precision, reliability, strength and service. Those are the reasons why we now are the world leader in ergometer bikes and the market leader in Scandinavia in transport bikes.

We manufacture, develop and market ergometers and exercise bikes, transport bikes and special bikes. Our largest customer groups are within health care, sports medicine, public authorities, industry and postal services.

For more information: <http://www.monarkexercise.se>



Thank you for choosing a test cycle from Monark!

Ideal position is important for a performance to reach its maximum and increases the potential for a perfect performance. The new setting options, along with an upgraded workload adjustment, make Monark's renowned bike even better.

- RC4 is equipped with a newly developed manual workload control, the workload is controlled by a lever located on the handlebar
- RC4 can be calibrated, both mechanically and electronically.
- RC4 has built-in pulse receiver in the display and can be used with a separate chest belt and some models have built-in pulse sensors in the handlebars at the seat



NOTE!

Use of the product may involve considerable physical stress. It is therefore recommended that people who are not accustomed to cardiovascular exercise or who do not feel completely healthy, should consult a physician for advice.

Product Information

Facts

NOTE! Before you start using the bike - remember to remove the pendulum locking devices and protective tape on the flywheel.

Technical details

Length	1405 mm
Width	640 mm
Height (max at display)	1240 mm
Height (max at saddle)	1240 mm
Weight	107 kg (estimated)
Weight flywheel	20 kg
Max user weight	250 kg
Painting	Industrial powder coating
Rust protection	Basic powder coating on exposed areas

Power output

Continuous (50-100 rpm)	15-700 W
Peak (at RPM)	1400 W (200 RPM)
Smallest increment	1 W

Technical data power adaptor

Input voltage: 100-240 V AC, 47-63 Hz

Output voltage: 12 V DC

Current: 2.5 A

Polarity: n/a

(Art. No: adaptor 9328-183, plug (EUR) 9328-192)



Included

- Chest belt
- Tool kit
- Power adaptor
- Calibration weight 4 kg

PC program

If you need a pc software to do exercise tests on the bike, our software is available for free download from our website: www.monarkexercise.se.

Serial number

The serial number is located on machine plate (5) according to *Fig: Adjustments* at page 7.

Initial operation

RC4 is mechanically calibrated in the factory. The user may wish to verify this by performing the mechanical calibration of the pendulum weight. See "Electronic calibration".

Apply power to the bike by first connecting the cable from the power adaptor to the recumbent at the power connector (3) at the right side of the bike, see *Fig: Adjustments*. Then plug the power adaptor into the wall outlet. Turn on the power switch and a green LED lights up.

The cable from the power adaptor can be locked with the clamp (15) which is placed below the power connection.

Perform the electrical calibration as specified in section "Calibration". Test by pedalling the recumbent. If the recumbent is working properly, it is ready for use

Power on crank or flywheel

Monark bikes measure the effect of the flywheel, so it will be a friction of 6-8% if you measure the impact of the pedals (measure the effect of the crankshaft, the difference is 4-5 %). These percentages will be primarily due to friction in the chain, pedals and bearings.

RC4 is set to measure the workload at the flywheel. The bike can be set to work with effect in the pedals / crankshaft (the cycle constant).

Cycle adjustments

Adjustments of the recumbent

Crank	Steel, 52T, 170 mm standard, 172.5 mm optional
Pedals	9/16" with foot straps
Seat	Recumbent seat
Handlebar	Not adjustable recumbent handlebar
Distance seat - handlebar	80-470 mm

Recumbent settings

When you ride on the recumbent you should adjust the distance to the pedals so that you get a comfortable seating position. You can adjust the seat longitudinally by lifting the lever on the right side and push the seat forward / backward. Once you find the correct position, release the lever and make sure it locks (a click is heard).

To change the seat-back tilt, pull out the sprint to the right and help with the other hand to change the tilt. Once you find the correct position, release the lever and make sure it locks (a click is heard). See *Fig: Adjustments*.

Fig: Adjustments

Length adjustment of seat

1) Lift the lever

2) Move the seat forward /backward

Adjustment of backrest tilt

3) Pull out the sprint

4) Adjust the seat-back tilt

5) Serial number

6) Power connection

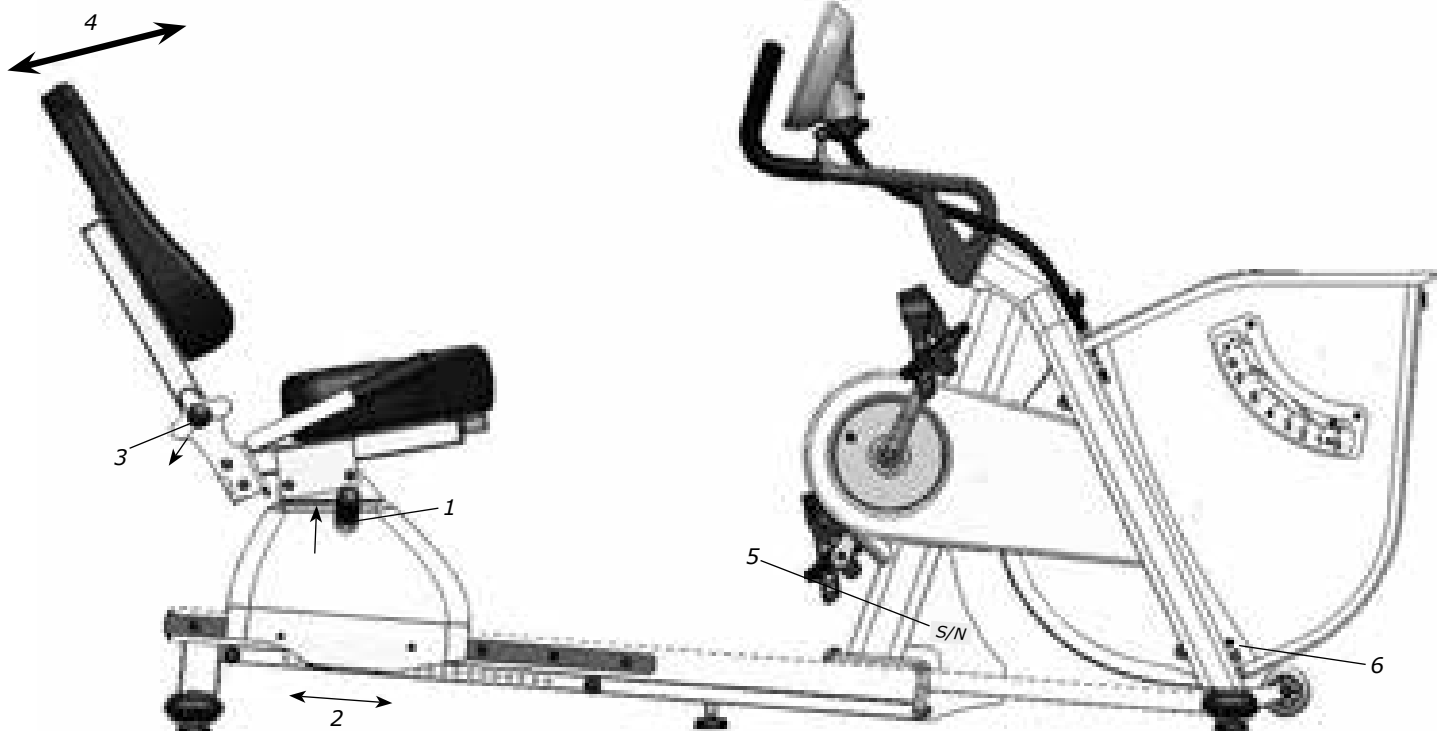

Power on crank or flywheel

Monark bikes measure the effect of the flywheel, so it will be a friction of 6-8% if you measure the impact of the pedals (measure the effect of the crankshaft, the difference is 4-5 %). These percentages will be primarily due to friction in the chain, pedals and bearings.

RC4 is set to measure the workload at the flywheel. The bike can be set to work with effect in the pedals / crankshaft (the cycle constant).

Calories

There have been different theories on how to calculate this, since it depends on several factors and this means that it can only be seen as an estimate.

As a standard calculation, when we display calories on our calibrated bikes, we use: 1 minute with 100W gives 7 kcal. It is easy to convert watts to calories if it is on the flywheel, the formula is $1W=0,2388 \times 10^{-3}$ kcal/s with four decimals. But when you normally show calories you want to show the total amount of calories your body has used during your training, not only the calories "burnt" on the flywheel.

We have chosen the formula given above that we think complies with the results given for a standard cycle position.

Validation

The following procedure ensures that the bike works for daily use.

- Check the HR function if you use chest belt, see section 'Heart rate'.
- Check the braking force by putting on a certain workload and check that the load is applied.
- Test by pedalling and check that a reasonable RPM is obtained - verify by a clock. Feel if the pedals move smoothly. Listen for unusual sounds. Fix if necessary.
- Adjust the handlebar and saddle and make sure they are securely attached and that the adjustment is working properly.
- Make sure the support legs are in position by rocking the bike. Tighten if necessary.

If something unusual is found during the daily inspection that you cannot resolve, please call customer service.

Pulse function

The user's heart rate can be measured with a heart rate belt that detects the pulse of the heart. Chest belt ANT+ is supplied as standard.

Heart rate monitoring requires that the chest belt is correctly placed. Make sure that your skin is clean where the chest belt should be placed. When it is correctly fitted the logo on the belt will be central and readable, outward and upright, by another person. The chest belt should be secured at a comfortable tension around the mid section, just below the breast muscle, see *Fig: Placement chest belt*. Moisten the electrodes before use, see *Fig: Moistening the electrodes*

NOTE!

Electromagnetic waves can interfere with the telemetry system. Cellular phones are not allowed to be used near the bike during test.

Pulse standard (chest belts)

The following pulse standard / chest belts can be used:

- Standard, uncoded 5K chest belts (5-5.6 kHz)
- Chest belts with ANT+

Short range ANT+: 0.6-0.8 m

Long range ANT+: 4-5 m

Range 5K: 0.8 m

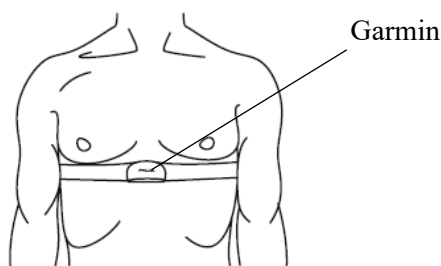

Fig: Placement of the chest belt

Pairing display and chest belt

Normally the display connects to the first ANT+ chest belt in "short range" and shows the heart rate until the chest belt is outside the "long range". If there is no ANT+ chest belt but a 5K chest belt in "short range", the heart rate from the 5K chest belt is displayed until the signal is lost.

ANT+ is prioritized and the first choice of the display. 5K is discriminated, but after 30 seconds with only 5K the display is locked to this chest belt as long as you do not lose the signal.

Monark Exercise AB recommend that you use an ANT+ chest belt for best function.

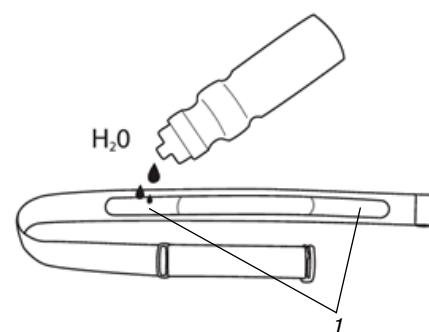

Fig: Moistening the electrodes (1)

Display Description

Display	
RPM	pedal revolutions / min
Heart rate (HR)	bpm
TIME	min:sec
Workload (WATT alt. kpm/min)	Watt
Speed	km/h
Distance	km
Calories (KCAL)	kcal
% Max HR	%

We recommend to always use the AC adaptor when using the bike. Without the AC adaptor, there will be no workload control and display alarm starts.

Calibration and basic settings are saved even when the power fails.

(The display can be powered by batteries, 4x1.5V, R14, but only when you make the basic settings.)

The display has the following functions:

- Settings for different units of measurement
- It is possible to calibrate the meter to get the correct workload
- Personal data such as age, max pulse, weight and gender can be set
- USB port for continuous output of data to an external computer
- Several different programs, see table "Available Programs"
- The meter also shows current pulse as percentage of max. HR
- The workload is rpm independent

If the values for rpm and watt start flashing during use, the set workload requires higher brake power than 7 kp. To solve this, increase the rpm or decrease the set workload.

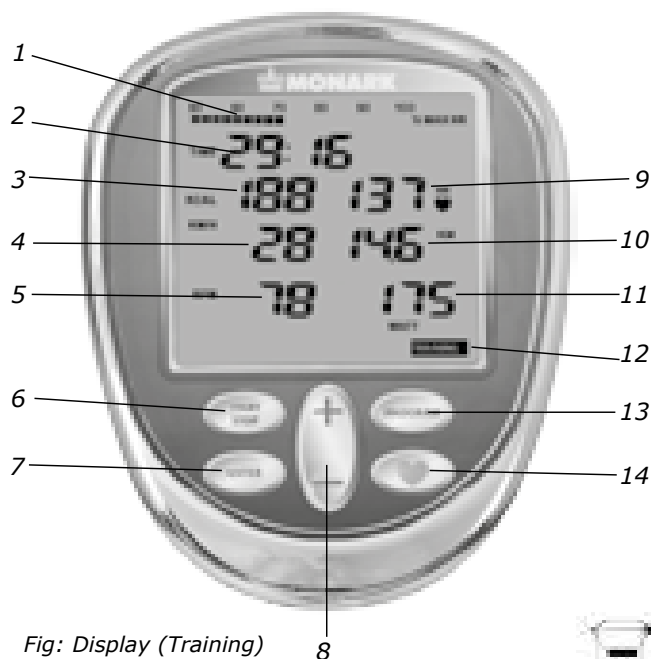

Fig: Display (Training)

- 1) % of max HR
- 2) Time
- 3) Kcal (estimated value)
- 4) Speed km/h
- 5) Pedal revolutions (rpm)
- 6) START STOP
- 7) ENTER
- 8) (+/-) button
- 9) Heart rate (HR)
- 10) Distance (km)
- 11) Workload (Watt)
- 12) Program
- 13) PROGRAM
- 14) HEART button



Available programs:

- Astrand
- YMCA
- PWC
- Increment
- METS
- Training

Sleep mode

Sleep mode is activated after 10 minutes if you do not press any button or if no rpm is recorded.

All settings are saved, but the personal settings are erased (to protect your personal privacy).

The meter wakes up when you press any button or if rpm is recorded. The meter goes directly to 'Quick start' (see separate section).

Personal settings

Usually you are asked to set the personal data needed when you start a program or a test. This data can also be set before, during e.g. "Warm up" in Training program with this function.

Press ENTER to enter the menu for Personal settings.

Set weight
dAtA
Weight kg 75

Set gender
dAtA
Kvinna
Man

Set age
dAtA
Age 35

Set max HR
dAtA
Max HR 185
The meter suggests an estimated max HR based on your age (220-age) Change if desired.

The display returns to start view.

The settings are saved until the meter goes into sleep mode. When the display wakes up the personal settings are changed to default values (this is to protect your personal privacy).

Alternative power / force display

The meter displays power in watts (default). If you want to display the power in kpm / min instead, press the HEART button for 5 seconds. Then you can switch between WATT, KPM / MIN and current kp-value using the (+/-) button. Press ENTER or wait 10 seconds to confirm and exit the setting.

NOTE!

Even if you select kp as unit, it is the power in watts which is set in the background when you press (+/-) button.

The displayed kpm / min is a simplified calculation (1 kp = 10 N) according to Astrand's tables.

(Although the displayed Kp value is correct and not rounded as above. For all calculations in the display the exact value is used, 1 kp = 9.80665 N)

Press HEART button for 5 seconds.

Set units
Default (kg, km, km/h, ml/min/kg)

Unit
KM/H KM
ML/MIN/ KG
KG

You can switch between these different power values.

Unit
KM/H KM
ML/MIN/ WATT
KG

When the unit you want to use appears in the display, press ENTER to confirm.

Unit
KM/H KM
ML/MIN/ KPM/MIN
KG

Unit
KM/H KM
ML/MIN/ KP
KG

The display returns to start view.

NOTE!
When you press the HEART button the meter starts searching for a HR signal. (Remember this if you also set the Steady State.)

User settings

Here you can make individual adjustments to optimize the bike for your needs on first use and when needed.

Press **ENTER and PROGRAM** for 5 seconds to set 'User settings'.

Set units
Unit: KM/H (KM), ML/MIN/ (KG)

Set cycle constant
ConStAnt: 1.00

Set metronome cadence
CAEnCE: 60

Set cycle-ID
Id00

Set base power
bASE: 25 WATT

Set steady State HR
St-StAtE: 3 HR

The display returns to start view.

If START STOP is pressed, or if no button is pressed for 20 seconds (in all steps) the changes are saved and the display returns to normal mode with the new settings active.

Units

Kg, km, km / h, ml / min / kg are default. You can switch between the different unit combinations with (+/-) button.

Cycle constant

The cycle constant is as default set to 1.00. Change using the (+/-) button.

When the cycle constant is set to 1.00 the power is measured at the flywheel. This is used in Astrand test, YMCA etc.

When the cycle constant is set to 1.05 the power is measured at the crank. This is often used on electronically-braked bikes.

Metronome cadence

Metronome diodes show pedalling revolutions (rpm) relative to the set reference value. The metronome is located at the back of the meter. The default value is 60 and can be adjusted with (+/-) button. The green LED in the middle flashes twice for each pedal revolution which helps to keep the right pedal cadence, see *Fig: Display* and *Fig: Metronome*.

The meter can be rotated so that the rider does not see the values in the display, but only sees the flashing diodes (in order to keep the right pedal cadence).

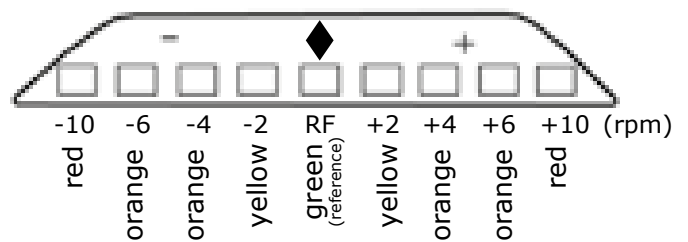

Fig: Metronome

BikeID

This ID is a parameter that the PC software can ask for. It is used to identify or number bikes when multiple bikes are controlled by same PC or similar.

Base Power

Default value which is used as "idle" power when no program or test is active. The default value is 25 but can be adjusted with (+/-) button.

Steady State HR

Default value is (\pm)3 but can be adjusted between 1 and 10 with (+/-) button.

Steady State (SS) HR is used only in Astrand program. SS is checked by comparing the mean value of HR during the period 4:45 to 05:00, and the mean time between 5:45 to 6:00. If the difference between these two values is the same or less HR is counted in SS.



Fig: Display
1) START STOP
2) ENTER
3) (+/-) button
4) HEART button (pairing display and chest belt)
5) PROGRAM
6) Metronome (on the back)

Calibration

NOTE!
Calibration can only be done from the display!

To perform the calibration, you use a 4 kg calibration weight.

- Zero the scale, see "Scale - Zero adjustment"
- Release the brake belt tension by lifting the pendulum over 0.5 kp (the motor starts).
- (The brake belt tension can also be loosened by running the engine manually. This is done by pressing (-) in the calibration mode.)



Check the potentiometer value at 0 kp.

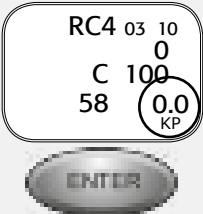

Move the pendulum to current value and hold it still until the potentiometer value stabilized.

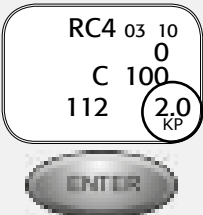

Press ENTER for next step.

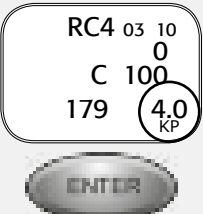

Repeat according to the pictures to the right

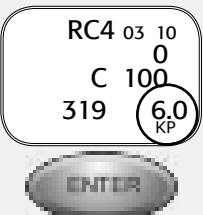

Two short beeps are heard and the calibration is finished.

The bike is ready to use.

If you have started the calibration mode but change your mind, you can press the START STOP button to exit without saving.
(However, if you press ENTER the calibration process has begun and must also be completed.)

Manual motor control

By pressing the (+/-) button in the calibration mode, the motor can be run manually if rpm is less than 30. This is to ensure the functioning of the engine for service or support, and to release the brake belt tension.

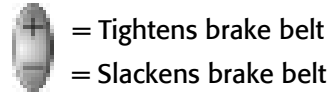

Current potentiometer value

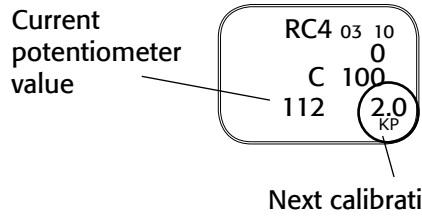

For best flexibility we recommend a potentiometer value between 40 and 60 at 0 kp.

Error message: CalErr - if the value is outside the window.

NOTE!

Potentiometer value shown in the photos are examples only, varies depending on the potentiometer value at 0 kp.

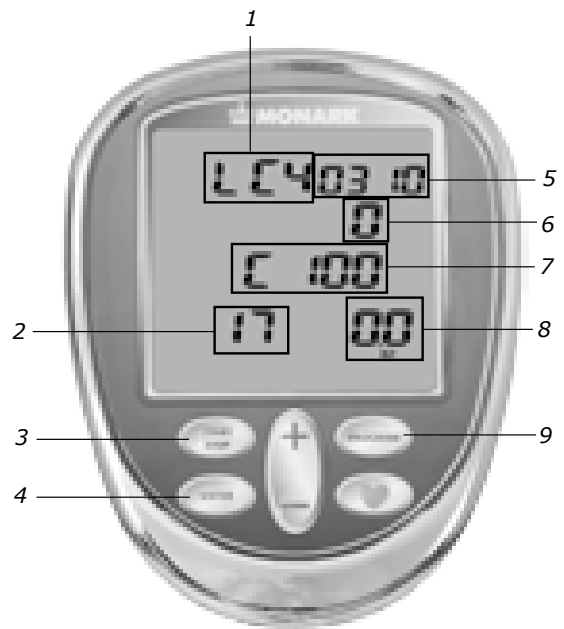

Fig: Display 'Calibration mode'
1) Bike model
2) Current potentiometer value
3) START STOP
4) ENTER
5) Software version
6) Hours in use
7) Cycle constant (1.00)
8) Calibration point
9) PROGRAM

Zero adjustment of scale

Check that 0-index (3) on the scale (2) is in line with the pendulum pointer when the bike is at a stand still and the brake belt is loose. If not, an adjustment must be done. Loosen the screw and adjust the scale. Tighten the screw (1) after adjustment. See *Fig: Adjustment scale*.

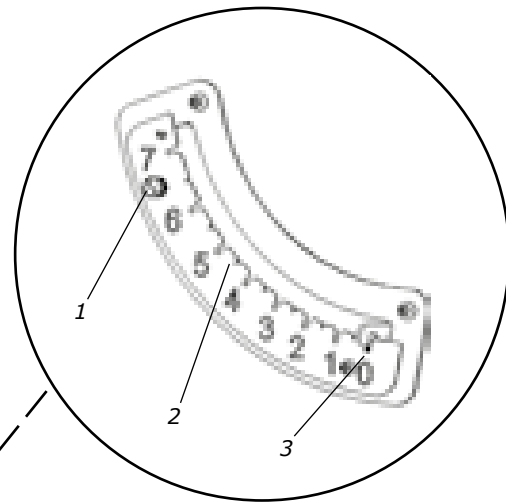

Fig: Adjusting scale
1) Screw
2) Kp-scale
3) 0-index

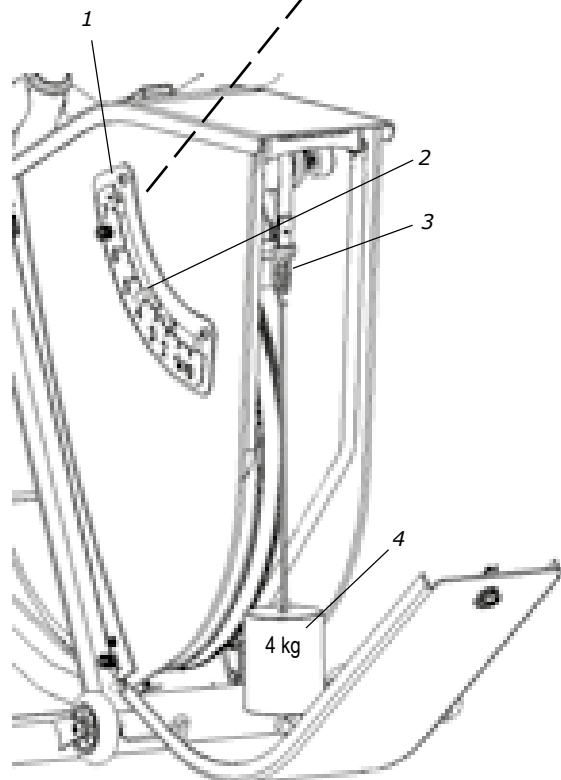

Fig: Calibration
1) kp-scale
2) Pointer
3) Spring
4) Calibration weight 4 kg

Calibration pendulum

All RC4 are calibrated in the factory, but a calibration of the pendulum can still be done to verify this. If so, please do the following.

Open the front cover. Check that the brake belt (3) is loose. If not, move the pendulum to 0.5 kp and hold it there a while to loosen it. Unhook the brake belt from the spring. Check that scale 0-index is in line with the pointer. Adjust if necessary, see section "Zero adjustment of scale".

A calibration weight 4 kg is hooked on the spring.

NOTE!

The flywheel must be completely stopped before the weight is hung on!

This weight (4 kg) can, when properly adjusted, be read at the corresponding point on the scale. If there is a deviation, adjust the pointer to the correct position by adjusting the weight (2) inside the pendulum. To change the adjustment weight loosen the adjustment screw (1). If the pointer shows too low, the internal weight must be moved upwards. If the pointer shows too high, the adjustment weight is moved down. This process is repeated until pointer is in the correct position. Hook the brake belt in the spring and close the front cover.

Check the calibration of the pendulum weight once a year or when needed.

Calibration electronics

Usually it is not necessary to recalibrate the cycle electronically, but it should be done after each service, change of electronic part, movement or if you adjusted the 0-index.

The calibration coefficient calculated by the computer is stored in main memory. No matter when the power is turned on, the last stored calibration will be placed in main memory. New calibration automatically replaces the old.

NOTE!

The pendulum must be kept still at the different positions. This is done by pressing down the pointer into the groove on the scale at each kp value.

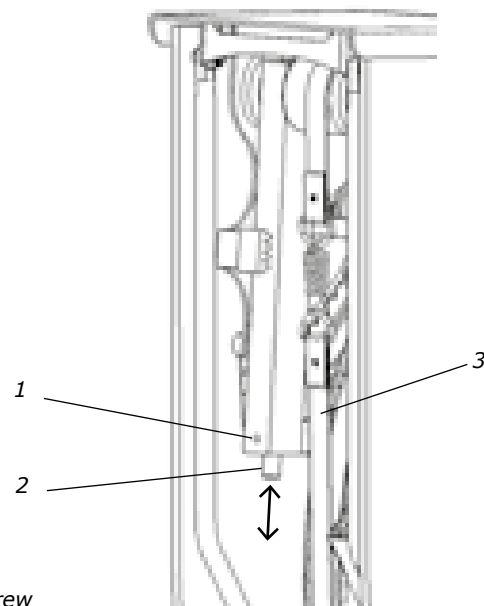

Fig: Pendulum
1) Adjustment screw
2) Adjustment weight
3) Brake belt

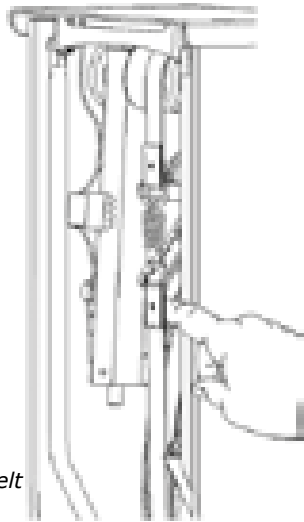

Fig: Control loose brake belt

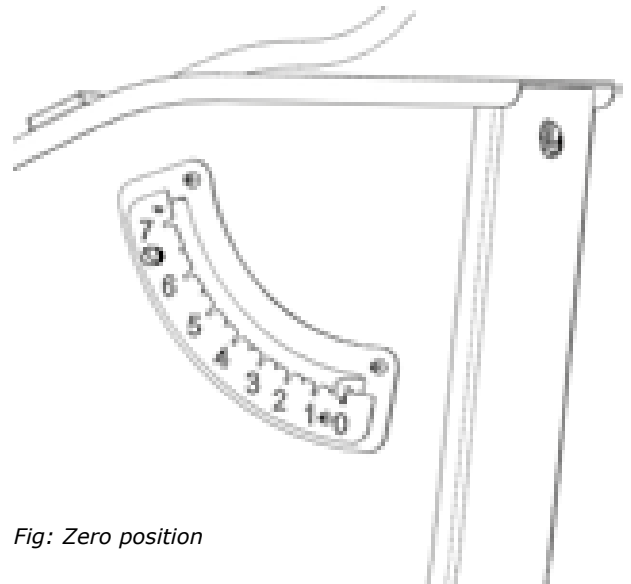

Fig: Zero position

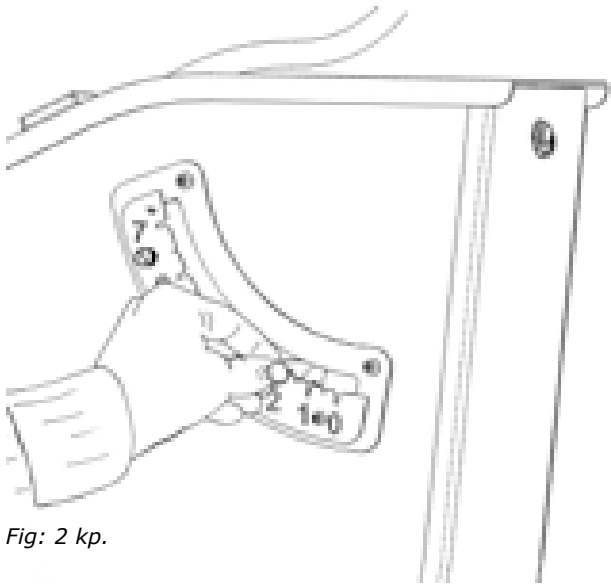

Fig: 2 kp.

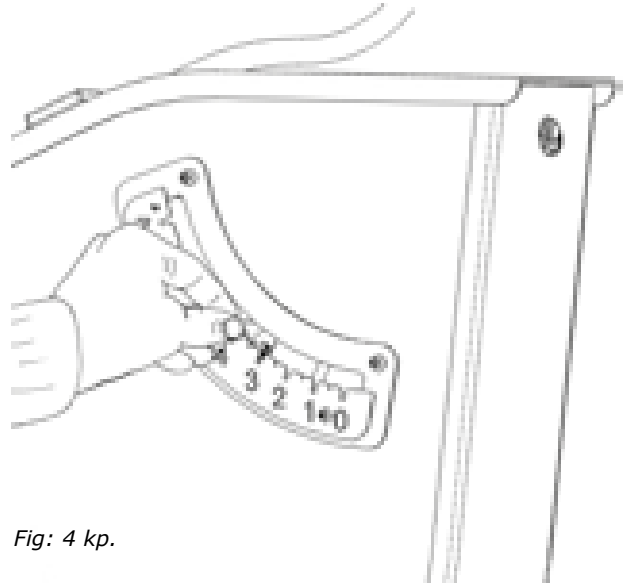

Fig: 4 kp.

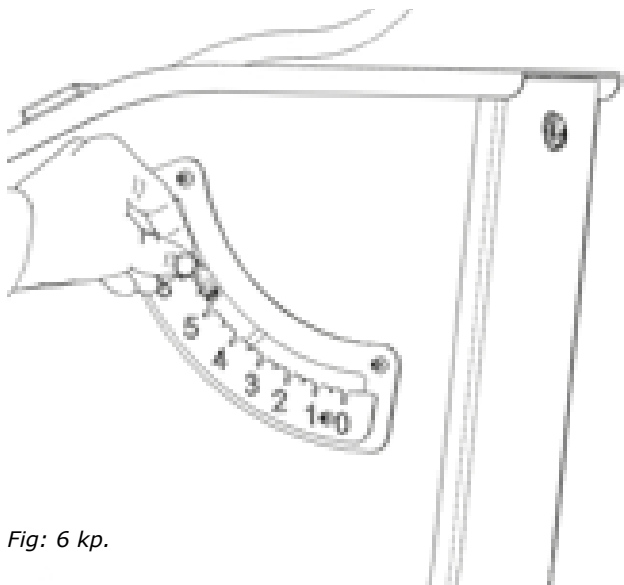

Fig: 6 kp.

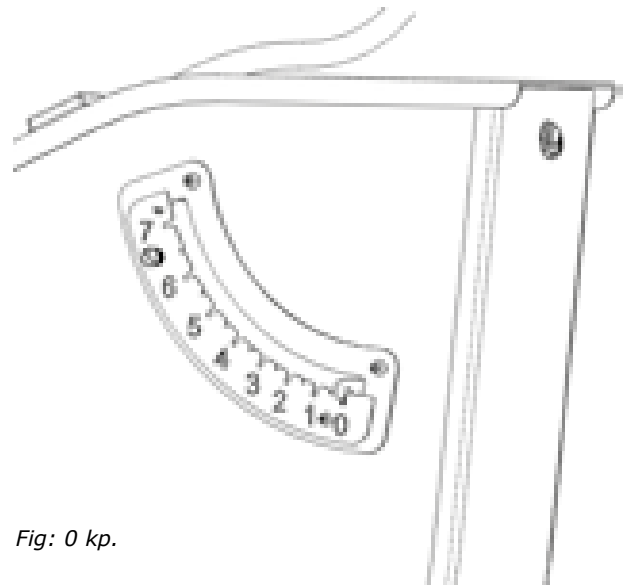

Fig: 0 kp.

Training

PROGRAM TRAINING

Personal data can be set for estimated HR (default HR is 185). See "Personal settings".

START STOP

Start Training program

TIME		
KCAL		HR
KM/H		KM
RPM		WATT

START STOP

Stop Training program

To end the Training program, press START STOP and the results are displayed on three pages.

Average value

TIME	tot	
KCAL	HR	
KM/H	KM	
RPM	WATT	

Min value

TIME	Lo	
KCAL	HR	
KM/H	KM	
RPM	WATT	

Max value

TIME	HI	
KCAL	HR	
KM/H	KM	
RPM	WATT	

Interval training

Start with eg. 300 W - press START STOP and the cycle goes down to the base power - press ENTER and the power returns to the previous power (300 W).

ENTER

Press ENTER (for 5 seconds during the test) and a new test is started with the same settings.

START STOP

Press START STOP (for 5 seconds during the test) and the test is reset.



QUICK START

'Quick start' can be used as a separate program. (If START STOP is pressed, the TRAINING program is activated.)

The program is active and starts with base power, adjust with the (+/-) button. No time is counted so the test person can warm up, use it as a 'quick start' or train without logging any values.

TRAINING

Press START STOP in 'Quick Start' and the display begins to show, count and log values. Press START STOP again and the test is completed and the results are displayed on three pages in the display and you can switch between the pages by pressing (+/-) button.

Workload adjustment

The power is adjusted with (+/-) button, press and hold for quick adjustment. The power can be set between 15 and 700 W in 5 W steps.

PROGRAM
METS

START STOP

dAtA
 Weight kg 75

Set weight

ENTER

dAtA
 Age 35

Set age

ENTER

dAtA
 Max HR 185

Set max HR
The meter suggests an estimated max HR based on your age (220-age) Change if desired.

ENTER

TIME
 METS HR
 L/MIN
 RPM WATT

Start METS program

START STOP

Stop METS program

To end the test, press START STOP and the results are displayed on three pages.

Average value

TIME **tot**
 METS HR
 L/MIN
 RPM WATT

Min value

TIME **Lo**
 METS HR
 L/MIN
 RPM WATT

Max value

TIME **Hi**
 METS HR
 L/MIN
 RPM WATT

ENTER

Press ENTER (for 5 seconds during the test) and a new test is started with the same settings.

START STOP

Press START STOP (for 5 seconds during the test) and the test is reset.



During the test METS and l/min. are continuously counted and displayed.

Calculation

METS values are displayed and calculated from the current workload. The two VO₂ values displayed during the test continuously calculate the average value for 5 seconds.

The formula used (values from ASTRAND original table) to calculate VO₂ at different workloads is:
 $0.2333 \dots l / kpm = 0.01428 L / W$ (2.8 l / min at 1200 kpm)

This is according to Astrand's table between 150 W and 300 W, and a good approximation for 15-700 W and a cadence of about 50-65 rpm.

References / Literature:

- Astrand P-O, "Ergometri - konditionsprov", Monark, Sverige
- Åstrand I, "Aerobic work capacity in men and women with special reference to age", Acta Physiol Scand. 49 (suppl. 169), 1960
- Astrand P-O, "Experimental studies of physical working capacity in relation to sex and age", Munksgaard, Köpenhamn, 1952.
- Astrand P-O, Rodahl K, "Textbook of Work Physiology", McGraw-Hill, New York, 1970.

Astrand

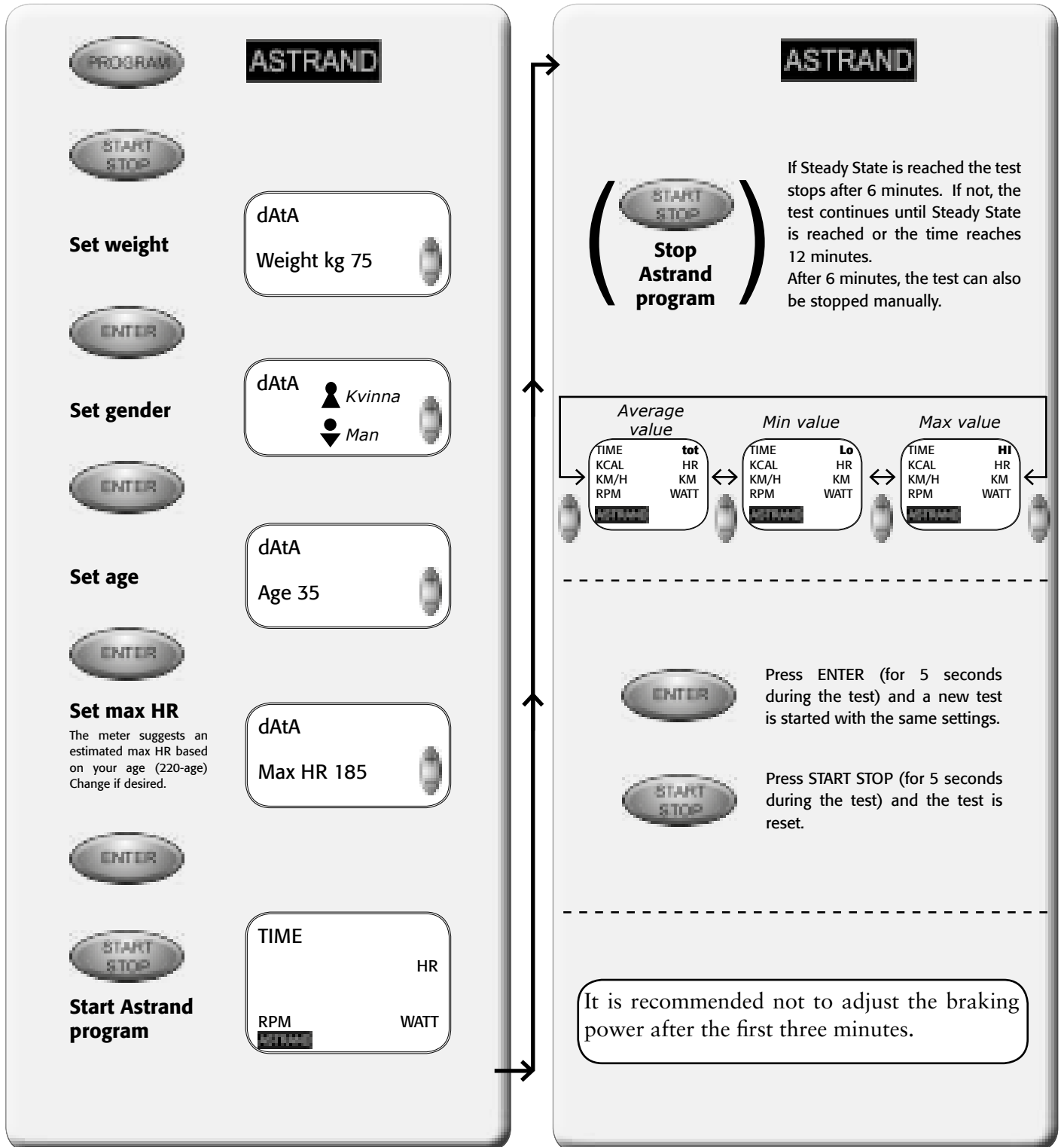

The test is automatically stopped after six minutes if Steady State (SS) is active. If not, the test continues until SS is reached or the time reaches 12 minutes.

Steady State (SS) is checked by comparing the average HR during the period 4:45 to 5:00 with the average HR during the period 5:45 to 6:00. If the difference between these two average values is the same or less considered SS.

When the test is completed the results are calculated and shown directly in the display.

You can stop the test manually after six minutes by pressing START STOP even if SS is not active (an error message is shown). The result is calculated and displayed.

Explanations to error messages:

LO Hr The end pulse is too low and outside the Astrand tables so no results can be calculated.

HI Hr The end pulse is too high and outside the Astrand tables so no results can be calculated.

Err Another reason why no results can be obtained.

No SS The test is cancelled manually without SS after 6 minutes or no SS at time 12 minutes.



References / Literature:

- Astrand P-O, "Ergometri - konditionsprov", Monark, Sverige
- Åstrand I, "Aerobic work capacity in men and women with special reference to age", Acta Physiol Scand. 49 (suppl. 169), 1960
- Astrand P-O, "Experimental studies of physical working capacity in relation to sex and age", Munksgaard, Köpenhamn, 1952.
- Astrand P-O, Rodahl K, "Textbook of Work Physiology", McGraw-Hill, New York, 1970.

YMCA

PROGRAM **YMCA**

START STOP

Set weight

dAtA
Weight kg 75

ENTER

Set gender

dAtA
Kvinna
Man

ENTER

Set age

dAtA
Age 35

ENTER

Set max HR
The meter suggests an estimated max HR based on your age (220-age) Change if desired.

dAtA
Max HR 185

ENTER

START STOP

Start YMCA program

TIME
HR
RPM WATT

Stop YMCA program

The test stops automatically after 6 or 9 minutes (depends on start HR)

ENTER

Press ENTER (for 5 seconds during the test) and a new test is started with the same settings.

START STOP

Press START STOP (for 5 seconds during the test) and the test is reset.

The test is automatic after it has been started. Two or three levels (6 or 9 minutes) run automatically according to the table on the next page.

After six or nine minutes the test stops automatically and the YMCA will stop flashing. The results are shown in the display.

You can stop the test manually after two levels (6 minutes) by pressing START STOP and the results are calculated if the values are within the tables.

If the test values are outside tables so that no results can be given, you will hear a long beep and an error message appears.

Explanations to error messages:

LO Hr The end pulse is too low and outside the Astrand tables so no results can be calculated.

HI Hr The end pulse is too high and outside the Astrand tables so no results can be calculated.

Err If the test is stopped manually too early, or other reasons that no results can be given.

References / Literature:

- Golding L. A, Myers C. R, Sinning W. E, Y's way to physical fitness“, YMCA of the USA, Rosemont, IL, 1982

Men:

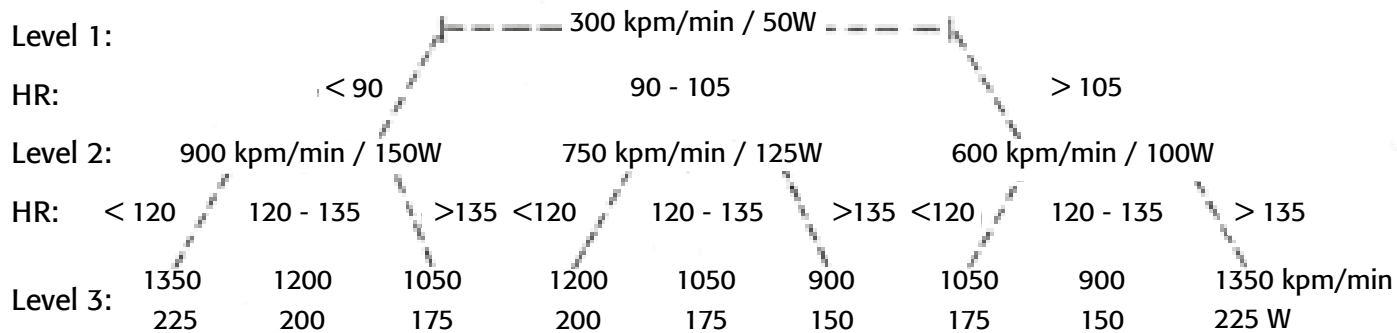

Women:

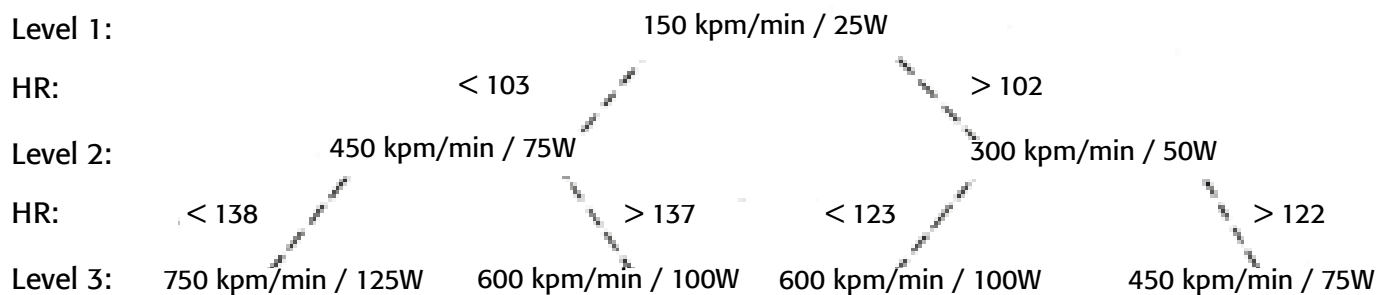

NOTE! The given HR values are at the end of each level



Increment

Increment

PROGRAM

START STOP

Set age

dAtA
Age 35

ENTER

Set max HR
The meter suggests an estimated max HR based on your age (220-age) Change if desired.

dAtA
Max HR 185

ENTER

Set time for each step

dAtA
TIME 3:00

ENTER

Set start power

dAtA
Init WATT 25

ENTER

Set power increase per step

dAtA
Step WATT 25

ENTER

START STOP

Start Increment program

START STOP

Stop Increment program

The test is stopped when:

- The cadence is <30 for more than 5 seconds
- When you press START STOP
- 700 W workload is achieved

Increment

The results are displayed on three pages that you switch between with the (+/-) button:

End value

TIME **End**

Puls

RPM WATT

+

Min value

TIME **Lo**

Puls

RPM WATT

-

Max value

TIME **Hi**

Puls

RPM WATT

-

NOTE!

If the meter does not get any rpm indication at start, the test stops. To restart, press ENTER.

ENTER Press ENTER (for 5 seconds during the test) and a new test is started with the same settings.

START STOP Press START STOP (for 5 seconds during the test) and the test is reset.

Current time → 204

→ *Remaining time to next step* 056

About Increment test

Increment is a testing protocol, where the power is increased according to a predetermined schedule. An increment is used to see the HR increase in relation to the rising power. It is used in both submaximal to maximal tests to track the maximum capacity.

The test continues until the test manager or test person cancels the test.

Time for each step

Set the time (minutes:seconds) for each single step. Pre-set time setting the first time is 3 minutes.

Start power

Set the first power level.

Power increase per step (step)

Set the power increase between each step of 5 to 200 W. Last value is presented as default.



Test procedure

The display begins with the start power (which is specified in "Start Power") and begins the countdown to the next step. The display will increase the power at the specified power increase each time the set time has passed and a new countdown begins. At the same time you hear a beep.

The test is automatic after it has been started.

If the test is stopped because of the low rpm it starts automatically even if the rpm increases again.







Set weight

dAtA
Weight kg 75





Set age

dAtA
Age 35





Set test level

P 150





The meter suggests a level based on your age and estimated max HR.

Set power increment per step

02:00
25 Watt

Power increase (two set)
25 W step 2 min / 50 W step 3 min



Set start power

Init
25 Watt



The test continues until the selected HR level is reached

TIME

NEXT

RPM

WATT

The program is automatic until the test HR level is exceeded.

Stop PWC program

The test is stopped when:

- HR level is reached (cool down starts)
- You press START STOP (if you press START STOP after the HR level reached the results are displayed)





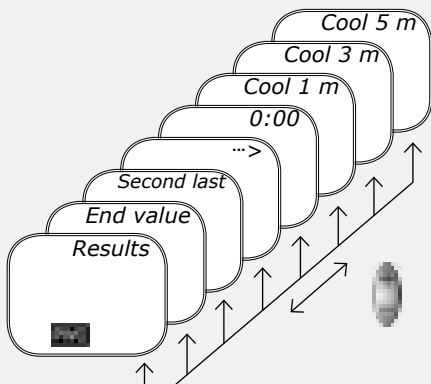



To see the results that appear on each page, see the table on the next page.



The test can always be stopped manually by pressing START STOP. Then the display shows the analysis pages but "Err" is displayed instead of watts value and watts / kg results, if the test is stopped before the countdown started and only the complete step the data is displayed.



Press ENTER (for 5 seconds during the test) and a new test is started with the same settings.



Press START STOP (for 5 seconds during the test) and the test is reset.



PWC test level

The meter suggests a level based on your age. Can be adjusted with (+/-) button.

Age (year)	Program
<30	P170
30-50	P150
>50	P130

Power step

The display shows time 2:00 and power 25 W. Switch with (+/-) button to time 3:00 and power 50 W. Press ENTER to save.

Start power

The display shows "Init". Set the initial power of the first step between 25 and 400 W with 25 W steps. Default value is 25 W. Press ENTER to save.

How it works

At the end of each step calculated average HR during the last 15 seconds, a beep sounds, 25 W or 50 W is applied workload, and a new countdown starts. In the first five seconds of the next steps the display shows test time, workload and estimated average HR during the previous step. During these five seconds the values flash.

This continues until the 15-second average HR is higher than the target HR (130 / 150 / 170). Then the test is stopped, a beep sounds, the workload reverts to start power, the final 15 seconds of average HR is displayed. The text "COOL" is displayed and the six-minute countdown starts. A 15-second average HR is displayed after 1, 3 and 5 minutes of the countdown.

You can skip the "cool down" by pressing the START STOP and the results appear instantly.

Results

After "cool down" two quick beeps are heard and the meter calculates and displays the results. The results are displayed on several pages that you switch between with the (+/-) button:

Page	Results that are displayed
Results	Total test time (end time), chosen test, total kcal, target HR, calculated result W_{PT}/kg and calculated result W_{PT}
End value	Total test time (end time), chosen test, target HR (end value) and calculated value per step
Second last	Second last test time, chosen test, step HR and calculated value per step
...>	Chosen test, step HR and calculated value per step
0:00	Test time, chosen test, start HR and calculated value per step
Cool 1 m	Time C1:00, chosen test and step HR
Cool 3 m	Time C3:00, chosen test and step HR
Cool 5 m	Time C5:00, chosen test and step HR

NOTE!

The displayed value for calories is the total estimated calorie consumption incl. "Cool down".

PWC target HR watt calculation:

The estimated watt value at target HR (WPT) is calculated from the following data:

W1 = Watts value set in penultimate step

W2 = Watts value set in the last step

P1 = 15-second average HR at the end of the penultimate step

P2 = 15-second average HR at the end of the last step

PT = Target HR: 130, 150 or 170 beats / min

Formula for the WPT:

$$WPT = W1 + (W2-W1) \times (PT-P1) / (P2-P1) \quad [W]$$

Relative WPT:

$$WPT / kg = WPT / Weight \quad [W / kg]$$

For further information please refer to the reference literature.

References / Literature:

- Dr. Theodor Stemper, Diplom-Sportlehrer
- ROST, R, H. HECK, W. HOLLMANN, Die Fahrradergonomie in der Praxis. Broschüre der BAYER AG
- STEMPEL, Th.: Gesundheit - Fitness - Freizeitsport. Bund-Verlag, Köln 1988 (zu beziehen über SSV-Verlag, Hamburg)

Testing using RC4

The versatility of the RC4 enables it to be utilized in a variety of testing environments. The precision and reproducibility of the test values obtained with the bike, along with the uncomplicated way to set up the tests, means the bike can be used in clinical work tests, in occupational health services for the fitness tests as well as fitness centers, schools, sports clubs and the like.

In general, one should note that stresses on the tested person can become quite severe, whether in a clinical work test or a simple fitness test in physical activity contexts. As a precaution, it may be advisable, prior to beginning an exercise protocol, that each test person consults with a physician.

Before testing, the test manager should review the entire protocol operation with the test person, explaining the work which will be required and the duration of the procedure. One should also agree on how the test person shall give signs of any fatigue, chest pain or other abnormal physical reactions.

The test person should not engage in heavy physical activity for several hours prior to testing to establish maximum oxygen consumption. In addition, all testing should be performed a reasonable time after meals. The test person should refrain from smoking within an hour of the testing period.

The test person should also wear suitable clothes. Training suit or loose-fitting clothing is best. More detailed instructions are rarely needed, regarding the ride, but it may still be appropriate for the test leader to give some advice on pedalling, saddle height and position of the handlebars. It should be comfortable to ride. Seat height should be set so that when the ball of the foot rests on the pedal the knee should be slightly bent when the pedal is in its lowest position.

Allow the test person to pedal at a low work load to experience how it feels to hold a steady RPM.

Finally, the chest belt shall be put on, see *Fig: Placement heart rate belt* in section "Heart Rate" for correct placement. Check for a minute that a proper heart rate is displayed. If you know the test person's normal heart rate you may also determine how nervous he / she is prior to the test. It may be appropriate to let the test person rest long enough before the test so a more or less stable resting heart rate can be read.

Test person enforcement

The bike performs automated tests virtually by itself, requiring minimal intervention by the test operator. This allows the operator to pay careful attention to the test person without distraction. The response to the exercise protocol can be accurately estimated and appropriate action taken to assist the test person, if necessary. Some programmes have sections where the test person may develop significant physical effort. The effect on the test person can not be underestimated.

During the test it is important to observe the test person's appearance and heart rate. The testing should be stopped immediately if the test person reports chest pain, difficulty in breathing, etc. A system of prompt medical attention should be set up prior to testing, in case of emergency.

The test person may also have difficulty in keeping a steady pedalling speed. This is of minor importance, except in cases where the program assumes a constant braking force, since the effect is automatically adjusted to the correct value as long as the pedal speed is at least 30 RPM. However, it is important to consider what each test documentation says about the pedal speed.

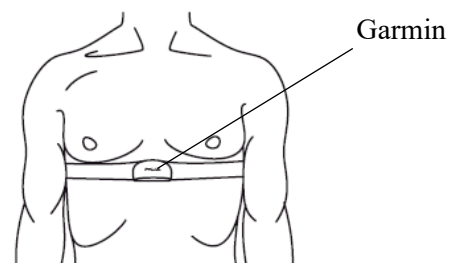

Fig: Placement of the chest belt

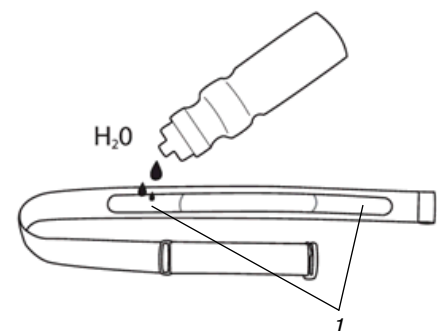

Fig: Moistening the electrodes (1)

Reviewing results

The maximum oxygen uptake is a standard measurement of the condition of the heart- and lung-functions. Dependent on the linear relationship between work and oxygen uptake and between work and heart rate, the heart rate response to work may be used to estimate the oxygen consumption. If the maximum heart rate is considered, the maximum oxygen consumption may be determined.

The YMCA and Åstrand protocols estimate the maximum oxygen consumption, based on a submaximal workload while all others report the oxygen consumption required by the final workload.

The estimated maximum oxygen consumption derived from some of the ergometer tests is subject to the error of the “age related predicted maximum heart rate“. Although there is a definite and linear relationship between work and oxygen uptake, there are some differences in actual oxygen uptake based on individual work efficiency. Test persons who are less familiar with bike exercise and those individuals who are less fit, are more likely be less efficient than those who ride bikes frequently.

It should be noted that these results are estimates or predictions of maximal response and have a greater chance of being in error than if the individual were tested to their actual maximum value. Interpretation should therefore be made more carefully with an understanding of the possibility of errors in the methodology.

Power calculation

1 RPM = a point on the flywheel moves 6 meters per minute.

50 RPM = 300 m / min

2 kp force gives $2 \times 300 = 600$ kpm / min

100 RPM = 600 m

1 kp force gives $1 \times 600 = 600$ kpm / min

Exact calculation:

Watts = RPM x kp x 0.98065

"Rule of thumb" calculation:

Watts = RPM x kp

(2% error, but may be good enough in many cases)

Troubleshooting guide

Symptoms	Probable Cause / Corrective Action
The display is not working	<ul style="list-style-type: none"> • Check that there is power in the socket and that no fuse has blown. • If there is power in the socket but the display still does not work, contact the <ul style="list-style-type: none"> • service centre.
LED does not light up	<ul style="list-style-type: none"> • No current in the wall outlet. Check the fuses. • Power switch disconnected on the bike. • Check cables and connections. • Correct power adaptor? Check that the transformer information (voltage, current, polarity, AC / DC) in section "Facts" complies with the transformer which is used.
No connection to PC	<ul style="list-style-type: none"> • Check cables (connections and type).
No workload	<ul style="list-style-type: none"> • Pendulum is stuck. Contact service centre for action / replacement. • Check calibration. • Check that brake belt is hooked in the spring.
No heart rate displayed	<ul style="list-style-type: none"> • Check that the battery is alright in the chest belt, moisten your thumbs and click on the electrodes, a low clicking sound will be heard at the battery cover, alternatively that the heart rate is displayed in the computer software. • Make sure the belt fits correctly on the test person, see <i>Fig: Placement of chest belt</i> in section "Heart Rate", and that the strap is sufficiently tightened. Moisten the electrodes, in severe cases it may be necessary to use gel alternative, one drop of dish washing liquid mixed in water. Pulse signal strength varies from person to person. Try the belt with a person known to have a good pulse wearing a chest belt.
Irregular heart rate	<ul style="list-style-type: none"> • Use an external unit, for example a HR watch, to check if it also indicates an irregular pulse. If this is the case, there is probably disturbance in the room. The disturbance may be electronic fields from power cables, elevators, lamps etc. or other electronic devices which are too close (e.g. cell phones). Move the bike to a different location in the room or change rooms. If an irregular HR remains it should be checked manually. If the HR remains irregular at work the person's health should be examined.
No RPM reading	<ul style="list-style-type: none"> • Check cable.
Unable to calibrate force	<ul style="list-style-type: none"> • The potentiometer shaft is not attached to the pendulum shaft, tighten the screw. • The potentiometer is misadjusted. Check the menu for calibration and that potentiometer value is within the recommended window. If not, contact service.

Symptoms	Probable Cause / Corrective Action
There is a click noise when pedalling (increases with the weight)	<ul style="list-style-type: none"> • The pedals are not tight. Tighten them or change pedals. • The crank is loose. Check, tighten. • The base bearing is loose. Contact your dealer for service.
CalErr shows in the display	<ul style="list-style-type: none"> • Incorrect calibration or not calibrated at all. Calibrate the Ergometer.
Scratching sound is heard when pedalling	<ul style="list-style-type: none"> • Check that the carriage block is taken off and that nothing is against the crank, chain, or wheel except the brake belt.
There's a click noise and a squeak noise when pedalling	<ul style="list-style-type: none"> • Loosen the chain.
Problems with the computer software	<ul style="list-style-type: none"> • Write an email (in English) to the software developer HUR labs support: support@hurlabs.com

Service

Note that the text about service and maintenance is universal and that all parts may not be relevant to your bike.

Note!

Make sure the voltage indicated on the appliance corresponds to the local mains voltage before making connections.

Warranty

EU countries - Private use

If you are a consumer living in the EU you will have a minimum level of protection against defects in accordance with EC Directive 1999/44/EC. In short, the directive states that your Monark dealer will be liable for any defects, which existed at the time of delivery. In case of defects, you will be entitled to have the defect remedied within a reasonable time, free of charge, by repair or replacement.

EU countries - Professional use

Monark Exercise products and parts are guaranteed against defects in materials and workmanship for a period of one year from the initial date of purchase of the unit. In the event of a defect in material or workmanship during that period, Monark Exercise will repair or replace the product. Monark Exercise will not, however, refund costs for labour or shipping.

Other countries

Monark Exercise products and parts are guaranteed against defects in materials and workmanship for a period of one year from the initial date of purchase of the unit. In the event of a defect in material or workmanship during that period above, Monark Exercise will repair or replace (at its option) the product. Monark Exercise will not, however, refund costs for labour or shipping.

Service check and Maintenance

It is important to carry out a regular service on your ergometer, to ensure it is kept in good condition.

Always keep the bike clean and well lubricated.

Service action:

- We recommend isopropyl alcohol to disinfect the surface of the bike. Use a damp but not wet cloth to clean the surface you wish to disinfect.
- Surface treatment with a rust inhibitor, especially when the bike is clean and the surfaces are dry. This is done to protect the chrome and zinc parts as well as the painted parts (4 times per year).
- Check now and then that both pedals are firmly tightened. If not the threading in the pedal arms will be damaged. When the ergometer is new it is important to tighten the pedals after 5 hours of pedalling (check this 4 times per year).
- Check that the pedal crank is secure to the crank axle (4 times per year).
- Be sure that the pedals are moving smoothly, and that the pedal axle is clear of dirt and fibres (4 times per year).
- When cleaning and lubricating be sure to check that all screws and nuts are properly tightened (twice a year).
- Check that the chain is snug and there is no play in the pedal crank (twice a year).
- Check that pedals, chain and freewheel sprocket are lubricated (twice a year).
- Be sure that the brake belt does not show significant signs of wear (twice a year).
- Check that the handlebars and seat adjustment screws are lubricated (twice a year).
- Be sure that all moving parts, crank and flywheel are working normally and that no abnormal play or sound exists. Play in bearings causes fast wearing and with that follows a highly reduced lifetime.
- Check that the flywheel is placed in the center and with plane rotation.
- Grind the brake belt contact surface, see section "Brake belt contact surface" (once a year).

Batteries

If the display is battery-operated, the batteries are in a separate package at delivery. If the storing time has been long the battery power can be too low to make the computer act correctly. Batteries must then be changed.

Flywheel bearing

The flywheel bearing is long-term greased and requires no supplementary lubrication. If a problem arises, please contact your Monark dealer.

Crank bearing

The crank bearing is greased and normally requires no supplementary lubrication. If a problem arises, please contact your Monark dealer.

Transportation

During transport the brake cord should be tightened to prevent it from falling off the flywheel.

Replacement of brake belt

To replace the brake belt remove covers if necessary. Make sure that the belt is loose.

Pendulum bike with engine:

To loosen the brake belt on pendulum bikes with engine, connect power to the unit and raise the pendulum to 4 kp. Hold it there until brake belt is loose. Please note how the belt is assembled. Remove it from the bike. Attach the new brake belt and assemble the bike in reverse order.

Weight basket bike:

To loosen the brake cord on cycles with a weight basket set the basket to its upper position. Loosen the lock washer that is holding the cord and remove it from the tension center. Loosen or cut off the knot on the other end of the cord and then remove the whole cord from the bike. When assembling a new brake cord, first enter one end into the hole in the tension center, tie a knot and let the knot fall into the bigger part of the hole. Lock the end of the cord with the lock washer.

Manual pendulum bike / exercise bike:

To loosen the brake belt on the bike remove all tension. Please note how the belt is assembled. Remove it from the bike. Attach the new brake belt and assemble the bike in reverse order.

NOTE!

When replacing the brake belt it is recommended to clean the brake surface. See "Brake belt contact surface".

Brake belt contact surface

Deposits of dirt on the brake belt and on the contact surface may cause the unit to operate unevenly and will also wear down the brake belt. The contact surface of the flywheel should be smoothed with fine sandpaper and any dust removed with a clean dry cloth.

Remove covers, loosen the tension on the brake belt and remove it. Grind with a fine sand paper. Grinding is easier to perform if a second individual cautiously and carefully pedalling the cycle.

Irregularities on the brake belt contact surface are removed by means of a fine sand paper or an abrasive cloth. Otherwise unnecessary wear on the brake belt may occur and the unit can become noisy.

Always keep the brake belt contact surface clean and dry. No lubricant should be used. We recommend replacing the brake belt when cleaning the contact surface. In regard to assembly and adjustment of the brake belt, see "Replacement of brake belt".

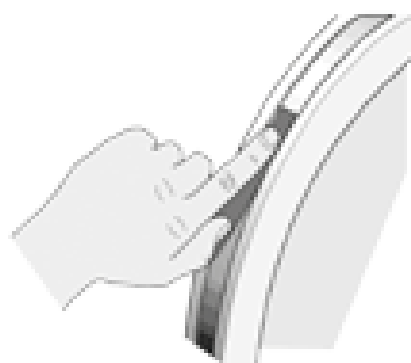

Fig: Brake belt contact surface

Chain 1/2" x 1/8"

Check the lubrication and tension of the chain at regular intervals. In the middle of its free length the chain should have a minimum play (1) of 10 mm (1/4 inch). See *Fig: Chain adjustments*. When the play in the chain is about 20 mm (3/4 inch) the chain must be tightened. Otherwise it will cause abnormal wear of the chain and sprockets. Therefore it is always recommended to keep the chain play as small as possible. Loosen the hub nut (2) on both sides and tense the chain with the chain adjuster (3) when needed.

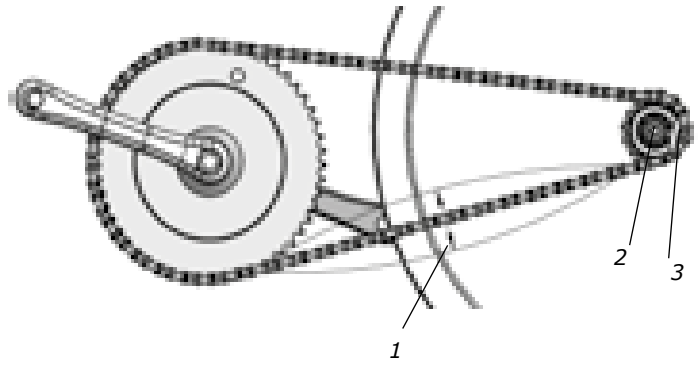

Fig: Chain adjustments

- 1) Chain play
- 2) Axle nut
- 3) Chain adjuster

When the chain has become so long that it can no longer be tightened with the chain adjusters it is worn out and should be replaced with a new one.

To adjust or replace the chain, remove covers if required.

To adjust the chain the hub nuts (2) should be loosened. Loosening or tightening the nuts on the chain adjusters (1) will then move the hub and axle forward or backward. Then tighten the nuts on the hub axle again. See *Fig: Chain adjustments*.

To replace the chain, loosen the chain adjusters as much as possible. Dismantle the chain lock (6) and remove the chain. Use pliers to both release the lock washer and assemble it again (4). Put on a new chain and assemble the chain lock. The chain lock washer should be assembled with the closed end in the chain's movement direction (5). See *Fig: Chain replacement*.

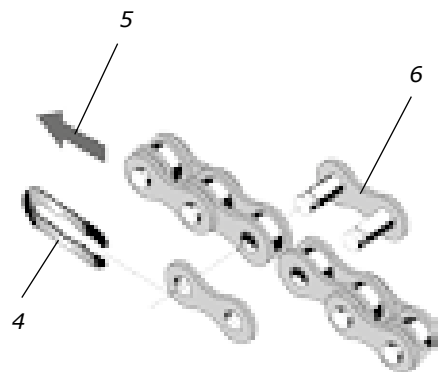

Fig: Chain replacement

- 4) Lock spring
- 5) Movement direction
- 6) Chain lock

NOTE!

At assembly the flywheel has to be parallel with the centerline of the frame. Otherwise the chain and sprockets make a lot of noise and wear out rapidly.

Then assemble the removed parts as above but in reverse order.

Freewheel sprocket

When replacing the freewheel sprocket remove frame covers if necessary. Remove the chain according to section "Chain 1/2" x 1/8".

Loosen the axle nuts and lift off the flywheel. Remove the axle nut, washer, chain adjuster and spacer on the freewheel side. Replace sprocket-adaptor and assemble the new parts in reverse order according to the above.

The sprocket should be lubricated with a few drops of oil once a year. Tilt the cycle to make it easier for the oil to reach the bearing. See *Fig: Lubrication*.



Fig: Lubrication



Fig: Hub assembly

Spare parts list

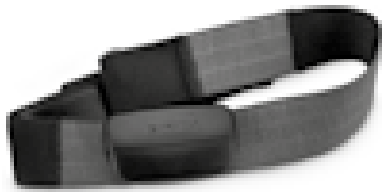
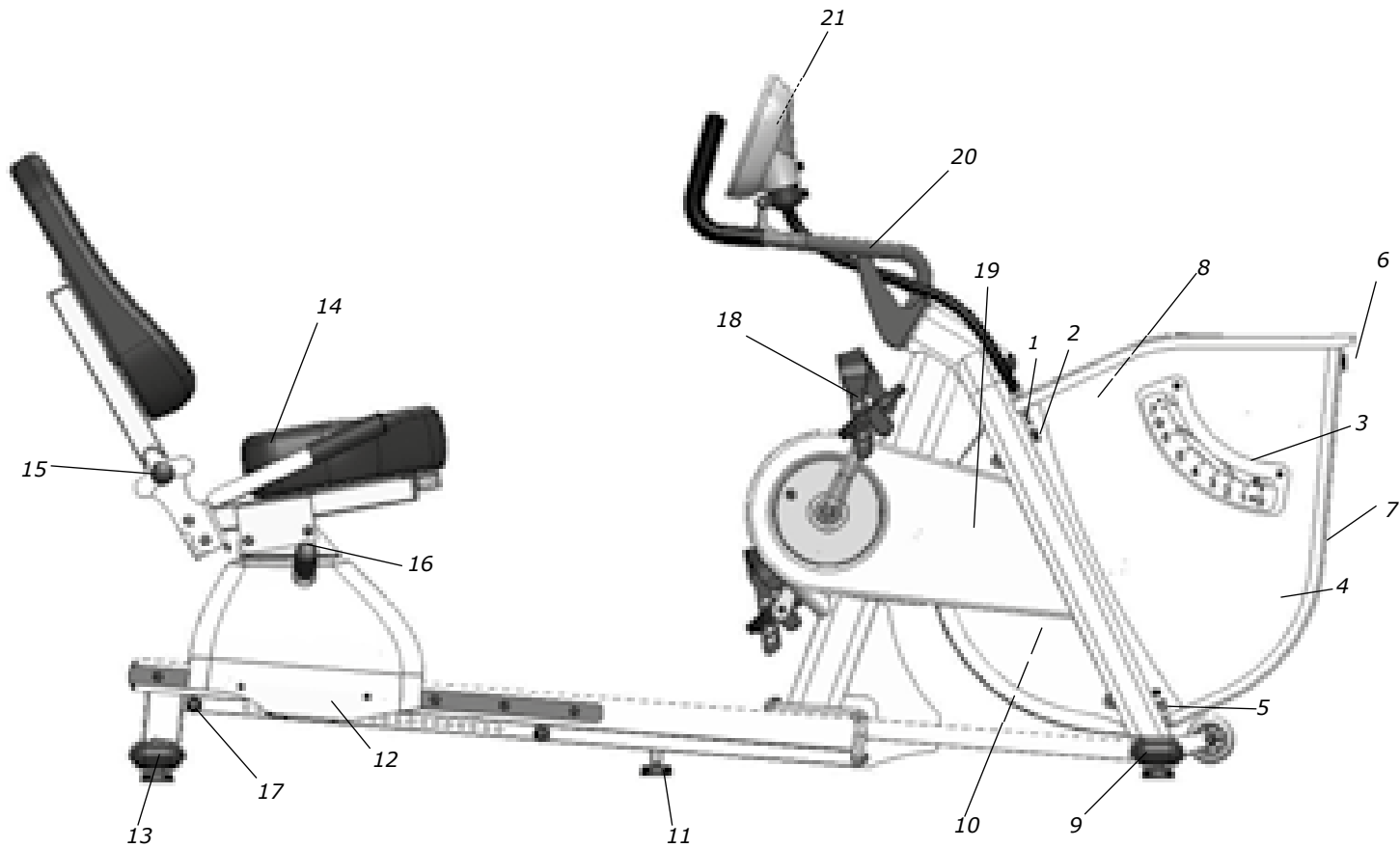
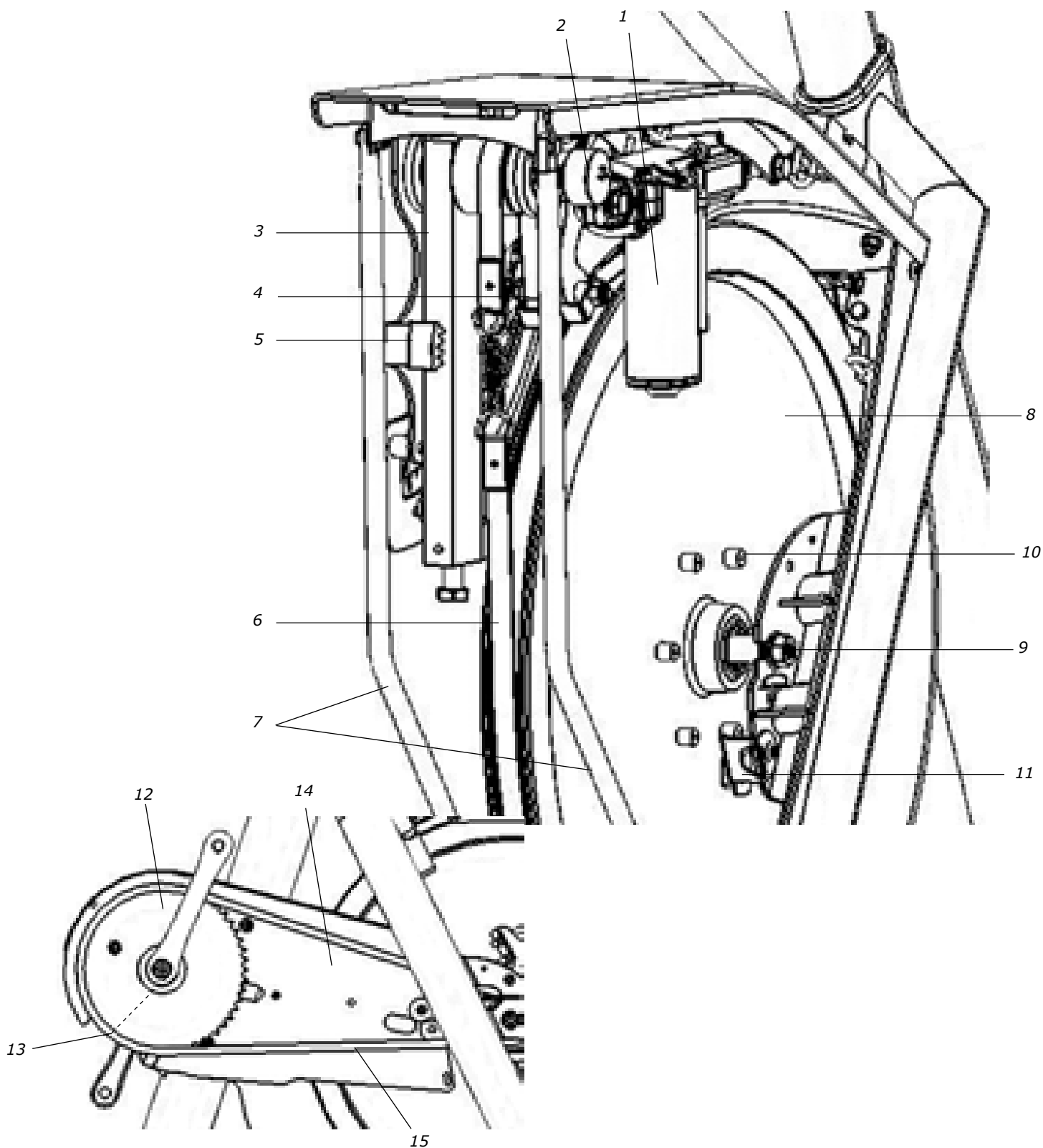

Fig: Chest belt



Fig: Power adaptor SE

Pos.	Qty.	Art. No.	Description	Pos.	Qty.	Art. No.	Description
1	1	9338-26	LED	11	1	9328-26	Rubber foot with screw M8
2	1	9310-72	Power switch	12	1	9327-84	Cover
3	1	9310-13	Scale 7 kp, complete	13	1	9301-145	Support tube rear, complete
	1	9310-152	-Scale		2	9309-51	-Plastic cap
	1	9000-103	-Pole screw M5x12, white		2	9328-26	-Rubber foot with screw M8
4	1	9310-620	Side cover, right	14	1	9329-3	Seat for recumbent, complete
5	1	8243-7	Holder for cable	15	1	9308-133	-Locking knob
6	1	9310-71	Lock to front cover	16	1	9326-97	Lever for length adjustment
7	1	9310-20	Front cover	17	2	9311-142	Stop
8	1	9310-630-1	Side cover, left	18	1	94435-1	Pedals for recumbent, pair
9	1	9301-4	Support tube front, complete	19	1	9311-36	Side cover rear, right
	2	9328-51	-Plastic cap	20	1	9311-86	Handlebar for recumbent, complete
	2	9328-26	-Rubber foot with screw M8	21	1	9311-165	Display
	2	9000-38	-Transport wheel, complete		1	9000-211	Calibration weight 4 kg
10	1	9310-605	Side cover rear, left		1	9311-75	Chest belt Garmin ANT+
	1	9000-103	-Pole screw M5x12, white		1	9328-183	Power adaptor AC 12 V, 2.5 A



Pos.	Qty.	Art. No.	Description	Pos.	Qty.	Art. No.	Description
1	1	9310-56	Motor package, complete	8	1	9300-31	Flywheel, complete
2	1	9311-67	Potentiometer with cable	9	1	9300-24	-Flywheel suspension, complete
3	1	9310-45	Pendulum 7 kp, complete	10	6	9326-164	-Magnets
	1	9310-43	-Pointer	11	1	9311-84	Sensor with bracket, complete
	1	9326-88	-Spring	12	1	9300-430	Crank steel, 52T, 170 mm standard
4	1	9100-26	Tension cylinder	13	1	9300-340	Cartridge bottom bracket 68/122 mm
5	2	9300-99	Stop	14	1	9311-6	Inner chain guard
6	1	9310-94	Brake belt, complete	15	1	9300-104	Chain 9300, 104 L, with chain lock
7	2	9310-65	Stay				



Version 1611
Art. No: 7950-412

